

B R O A D E N I N G Y O U R S C O P E

White Paper

Next Generation Video Compression: MPEG-4 AVC

September 2003



IVNTM YOUR WAY TO
VIDEO NETWORKING



Next Generation Video Compression: MPEG-4 AVC

WHITE PAPER SEPTEMBER 2003

In the broadcasting industry, the drive to achieve better utilization of the existing bandwidth has increased in the last few years for the following reasons:

- Cables companies want to offer more added value services, which consume a lot of bandwidth,
- Telco companies are increasing their service portfolio, and beginning to penetrate the broadcast world, offering broadcast channels in addition to data and telephony services.
- Satellite companies are fighting to reduce costs.

A number of compressions standards have matured to the level where they are becoming attractive alternatives to the current MPEG-2 standard. One of the main candidates are WM9 and MPEG-4 AVC (Advanced Video Coding, also known as MPEG-4 part 10). Due to its compression efficiency, MPEG-4 AVC standard is expected to become popular with traditional segments and standards, such as the DVB. This paper reviews the MPEG-4 AVC developments and improvements.

Digital video compression background

The standardization in digital video compression is lead by the ISO (International Standards Organization) and the ITU (International Telecommunications Union) organizations.

Most video compression standards are based on the H.261 standard principles, designed by ITU. Its follower, the H.263 standard, was presented few years later, demonstrating significant improvements. After finalizing the original H.263 standard for video telephony in 1995, the ITU-T Video Coding Experts Group (VCEG) started working on a long-term effort to develop a new standard for low bitrate visual communications. This effort led to the H.26L standard draft, offering significantly better video compression efficiency than previous standards.

In parallel, ISO Motion Picture Experts Group (ISO-MPEG) presented the MPEG-1 standard aimed for the PC/CD World. Next, the MPEG-2 standard was introduced for the broadcast world, using high resolutions and medium to high bitrates. In addition to its video coding, MPEG-2 includes audio coding and transport layer for handle multiple programs. Today, the MPEG-2 standard is the common standard for broadcasting and one of the building blocks of standards such as the DVB and ATSC.

For several years, MPEG-2 has been improved, but it is reaching its theoretical limitations. Additional improvements were attempted, using other techniques, such as fractals and wavelets, with no significant improvements in video compression results.

Figure 1 shows a timeline of the standards development.

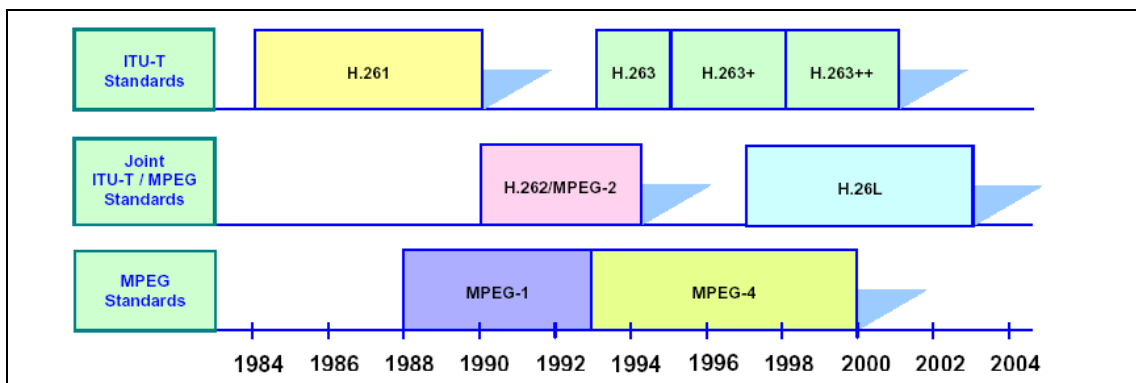

Figure 1. Progression of standards developments for broadcasting

The original MPEG-4 standard attempted to bring the object-oriented perception into the compression world, with limited success, due to its complexity and overhead.

In 2001, the ISO-MPEG recognized the potential benefits of the ITU-T H.26L standard, and the Joint Video Team (JVT) was formed, including experts from MPEG and VCEG. The main task of the JVT is to develop two identical standards; ISO MPEG-4 Part 10 and ITU-T H.264. The official title of the new standard is MPEG Advanced Video Coding (MPEG-4 AVC). However, it is widely known by its former working title, H.26L and by its development team name, JVT.

The new MPEG-4/AVC standard is due in 2003 and claims to provide more than double the compression ratio of MPEG-2. The MPEG-4 AVC will use AAC (the MPEG equivalent of Dolby AC-3) as its audio definition and the MPEG-2 and MPEG-4 definitions for the transport layer.

Challenges for a next generation video compression standard

The adoption of the MPEG-2 video compression standard and its video compression technology has been the factor behind the success of television broadcast to the home over the past seven years. This technology provided a huge jump in the number of channels that could be economically broadcasted.

During recent years, additional improvements were made (outside the standard) in order to reach lower bitrates. These improvements include preprocessing, noise reduction and “look a head”/”dual pass” techniques. However, there is a consensus that the current standard is reaching its limit in the compression ratio and will it not be able to deliver quality video in bitrate lower than 1 Mbps. Yet, due to the fact that most of the currently used set-top-boxes (STB) support MPEG-2, this standard probably will remain widely popular in the next few years.

Bandwidth limitations have always been the weak point of the digital broadcast market. The need for wider bandwidth for video broadcasting was and always will be relevant for both the Direct to Home (DTH) and Contribution and Distribution (C&D) markets.

Direct to Home (DTH) market

The Direct-to-Home (DTH) video broadcasting market refers to the moving of content from a broadcasting station (headend) to the subscriber homes. This market is functionally divided into Satellite, Cable and Telco markets. Each one of these segments refers differently to the impact of the next generation of video compressing standards.

Satellite DTH Market

The Satellite DTH market requires more effective utilization of the bandwidth due the high cost of transponders. The new compression standard will be able to significantly decrease the needed bandwidth and thus to dramatically lower the average cost for each service (for example, provide an average of less then 1 Mbps for each individual service).

Cable DTH Market

Facing the triple play challenge, the Cable DTH market will probably develop into two directions. First, support of advanced telephony and data delivery. Second, using existing bandwidth to provide high quality value-added services, such as Video-on-Demand, (xVOD), High Definition TV (HDTV) and HD-VOD , time shifting capabilities, iTV services. These services demand tremendous of bandwidth. Therefore, the cable market needs an effective way to utilize bandwidth to prevent expensive changes and upgrades in infrastructure.

Telco DTH Market

The current bandwidth limitations of Telco infrastructures limit the supply of effective bandwidth to subscribers. Even with the currently available technologies, the relevant bandwidth accessible to each subscriber is less than 2 Mbps (for data, audio, video). New compression techniques should enable the Telco companies to provide quality video services, including broadcasting and value-added services.

Contribution and Distribution (C&D) market

The Contribution and Distribution (C&D) market refers to moving information within the network, between production studios and within the various headends throughout the distribution network.

The C&D industry may take more time before bandwidth utilization becomes a critical issue. However, once new standards reach levels of double the compression provided by MPEG-2, the transition to the new standard will be easy, as the C&D market does not require the and vast investments in STBs.

Moreover, MPEG-4/AVC will use the same transport as the current MPEG-2 is using. It is quite likely that there will be a transitional period when broadcasting uses a multiplexed stream, combined from both MPEG-2 and MPEG-4/AVC standard based programs.

Current MPEG-2 Video Compression standards

The MPEG-2 video compression standard is based on removal of redundant information. Processes like DCT, motion estimation, quantization and statistical coding are used to remove redundant information, using similarities in the spatial and temporal domain.

The current MPEG-2 standard uses several building blocks such as sequences, Group Of Pictures (GOP), frames, slices, macro blocks and blocks. Additional techniques were added to reach higher compression ratio while maintaining a high quality video. These techniques include preprocessing, dual pass and post processing. The MPEG-2 technology has also provided a huge step jump in the number of channels that could be economically broadcast.

Figure 2 demonstrates how an MPEG-2 based encoder is using the MPEG-2 technology and the MPEG-2 encoding building blocks.

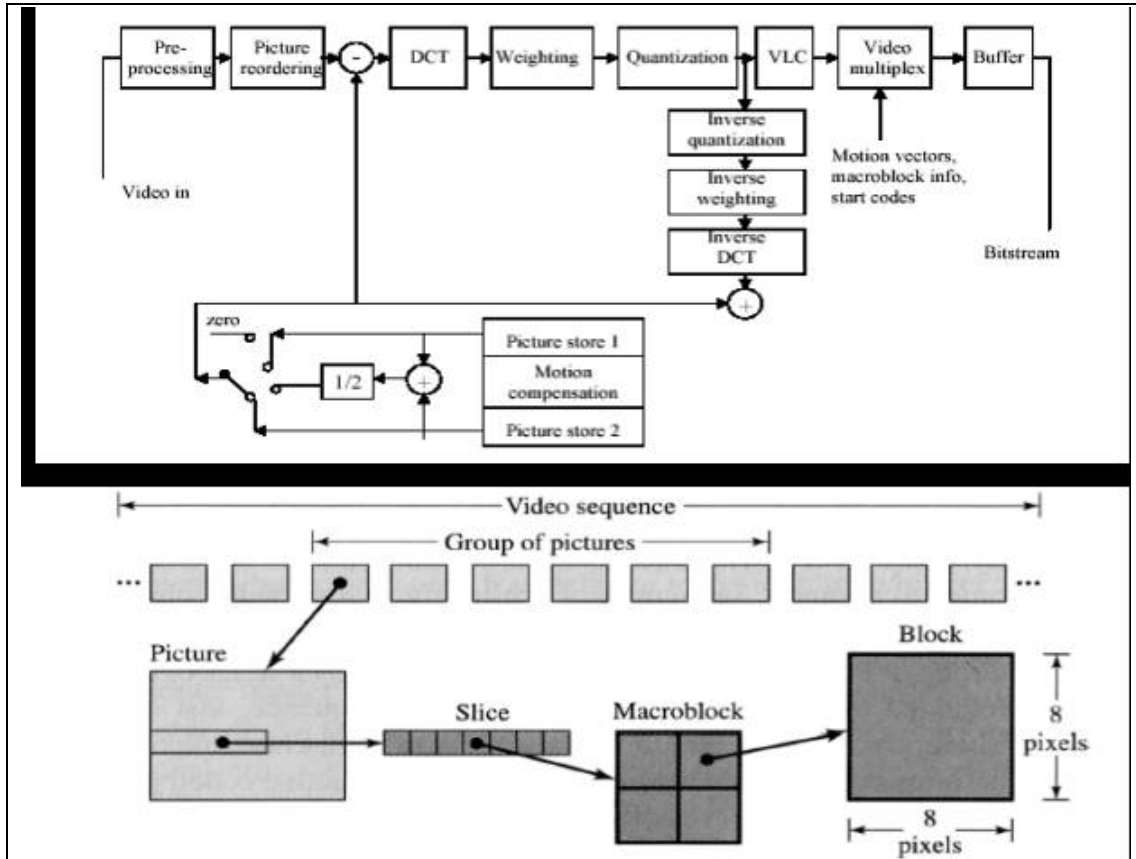

Figure 2. MPEG-2 encoding

MPEG-4 AVC compression standard

As in the earlier standards (such as MPEG-1, MPEG-2 and MPEG-4), the H.264 draft standard does not explicitly define a CODEC (enCoder / DECoder pair). Rather, the standard defines the syntax of an encoded video bit-stream together with the method of decoding this bit-stream.

The new MPEG-4/AVC standard is due in 2003 and claims to provide more than twice the compression ratio in comparison to MPEG-2. It does not attempt to handle problematic features such as scalability, object handling, sophisticated program layers and others. The basic functional elements of the MPEG-4/AVC (prediction, transform, quantization and entropy encoding) are different from previous standards.

The important changes in the MPEG-4/AVC occur in the details of each functional element.

Figure 3 illustrates adaptive division of macroblocks in the MPEG-4/AVC encoding technique.

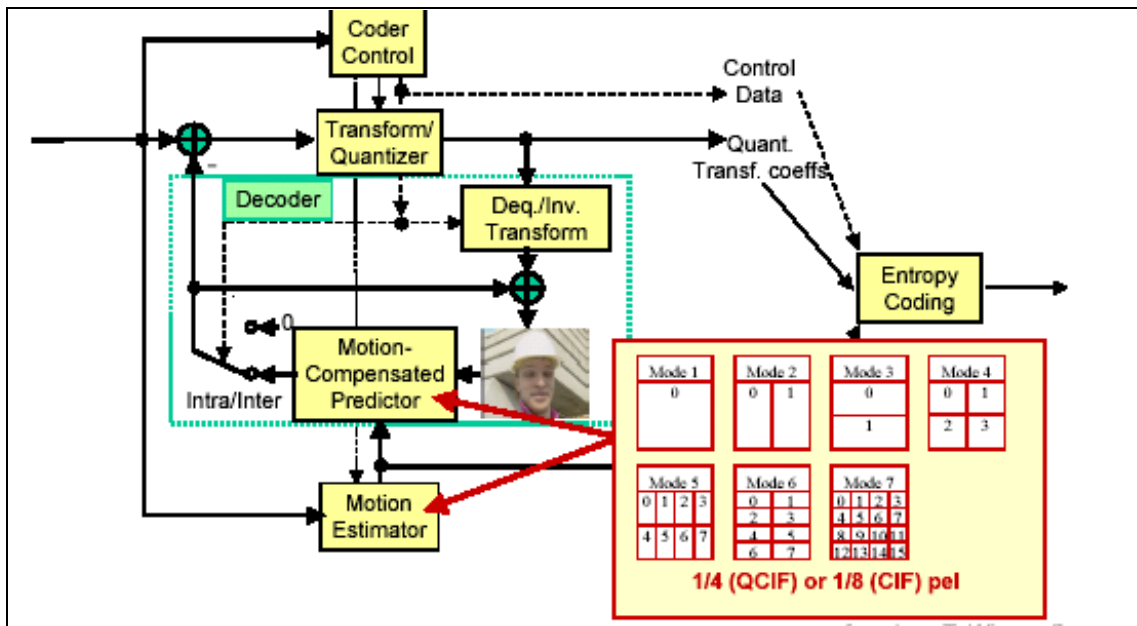

Figure 3. Macroblock division

An improved division of the traditional macroblock was changed. Adaptive and flexible division was adopted.

Improved techniques for motion estimation were also adopted, allowing multi references frames and increasing the temporal redundancy utilization. Other techniques were added, such as integrated filtering, better predictions, adaptive entropy coding, and a better quantization system. The result is compression and video quality improvement.

Figure 4, page 9 illustrates multiple reference frames for motion estimation in the MPEG-4 AVC encoding technique.

Barrier to change

The huge number of deployed MPEG-2 STBs is the barrier which may hold back the move to the next generation video compression standard. The available STBs will not be able to support the new, advanced standards.

Moreover, since the complexity of the new standard is much higher than the MPEG-2, manufactures of future STBs will have to implement hardware changes and overcome the costs of higher processing power.

Finally, moving to new standard require changes throughout the entire network. Changes in a wide range of hardware are required, including encoders, decoders, multiplexers, transraters, and other broadcasting equipment.

In C&D, the move to the new standards could be simple, as it is based on professional equipment with limited deployment. In contrast, DTH is based on STBs located in the subscribers' home. Here the expenses are tremendous, the variety is great and a across-the-bard replacement move is unacceptable due to the high cost.

Gradual transition

In the DTH world, the new standard will be used primarily at the edge points/last mile. Telco and Cables companies will allow scalable penetration in new regions and for new subscribers, depending on the development cost-effective availability of STBs.

- Telco companies will be able to use the new standard, because they do not have issues of STBs, and their transport layer is constant bitrate. The Telco market, where standards are not strongly established, can use MPEG-4 AVC as well as WM9 standards.
- Cable companies will be able to use the new standard for new services (xVOD), requesting the subscribers to replaces their old STBs in order to register to the new services

In the foreseeable future, equipment will support combinations of current standards in combination with future standards. Hardware platforms will simultaneously process MPEG-2, MPEG-4 AVC and possible WM9.

Conclusion

In the broadcasting industry, MPEG-2 will inevitably be replaced by new standards in the coming years, most likely MPEG-4 AVC or WM9. This transition will be gradual, and systems may support several standards at once. Currently broadcasters are confused as to what standard to adopt, and many are waiting to see what technology picks up the greatest momentum.

It is widely recognized that both MPEG-4 AVC and WM9 offer superior performance over the older standards in the areas most important to broadcasters in both DTH and C&D segments. Telcos will have the easiest time making the change, with cable and satellite broadcasters following suit.

Scopus is a leading provider creating multiple-standard equipment to handle both present and future developments in compression standards. The Scopus platform includes capabilities for transcoding (conversion) between the different formats. Scopus has developed a generic hardware platform for simultaneous support of multiple codecs.